

LIEBHERR A922 RAIL

22T WHEELED RRV



COMPACT & FLEXIBLE. THE PERFECT COMBO FOR MAXIMUM PERFORMANCE

PERFORMANCE

Compact, flexible and super powerful road rail excavator capable of dragging long lengths of rail. Super heavy lift capacity and the capability of towing 120 tonne of wagons.

RELIABILITY

Turnkey road rail solution from one OEM.

COMFORT

Ergonomic excellence – superior cab design for operator comfort and second cab for protection officer or supervisor.

MAINTAINABILITY

Service is simple and easy with our 24/7 on call emergency team ready for any breakdown.



WORKING SPECS

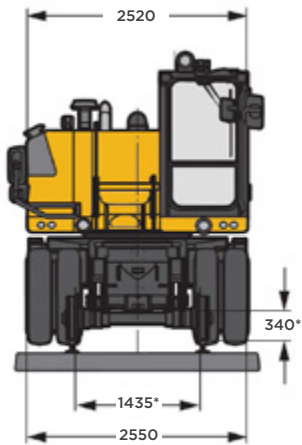

*without outriggers / Symetric Rail mm

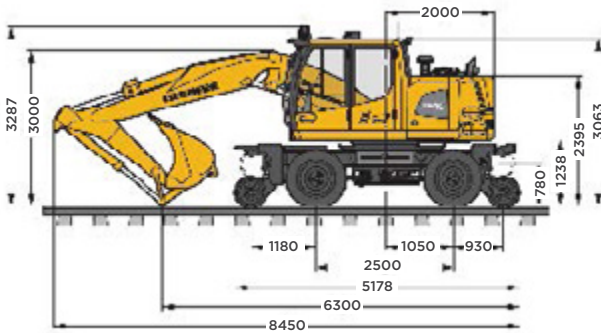

** Note sizes may vary



CAPABILITIES

- Optimised dipper arm design for application under overhead electrical wiring with height and slew restrictor's
- Standard and broad gauge capability
- 120 tonne towing capacity
- Superior lifting capacity's with in OEM rated capacity indicator

SPECIFICATIONS

- Weight 22,800kg
- Engcon tilt rotator with integrated grab
- Huge range of attachments available
- Side and rear cameras
- 20 km/h step less speed control
- All rail wheel fail safe braking
- 8 wheel service braking

RAIL NETWORKS APPROVED TO WORK ON:

- TfNSW
- John Holland
- ARTC
- MTS

