

HITACHI ZX95-RRmg

# 9T CRAWLER RRV



## THE MULTI GAUGE 95T ROAD RAIL EXCAVATOR

The ZX95 Multi Gauge (mg) is a newly developed concept road rail excavator completely designed and built in house by the Anric Engineering division.

Based on the Hitachi hydraulic excavator, this road rail excavator is the Mark 3 of its design and field testing, and it continues to show outstanding results. This road rail excavator is the most advanced ever built in its size class. Boasting a huge safe working load (SWL) combined with its compact size and an undercarriage that has been narrowed, to engineer a number of risks out of the design of many road rail excavators on the market.

- 1100kg on rail SWL full 365° at full reach
- Long reach
- Short tail swing
- Engcon Tilt Rotator system

Some of these risks are associated with on / off tracking and damaging the rail. This new and improved road rail excavator exhibits benefits in many areas; Tier 3 engine for a smaller environment footprint, improved fuel efficiency and exceeds compliance of AS7081.

The ZX95RRmg is one of the safest and the best in its class around the world and is ready for your next project.

- Gauge convertible Narrow, Standard & Broad
- High and slew restrictors
- Capable of towing both front and back and has a 20t towing capacity

# WORKING SPECS

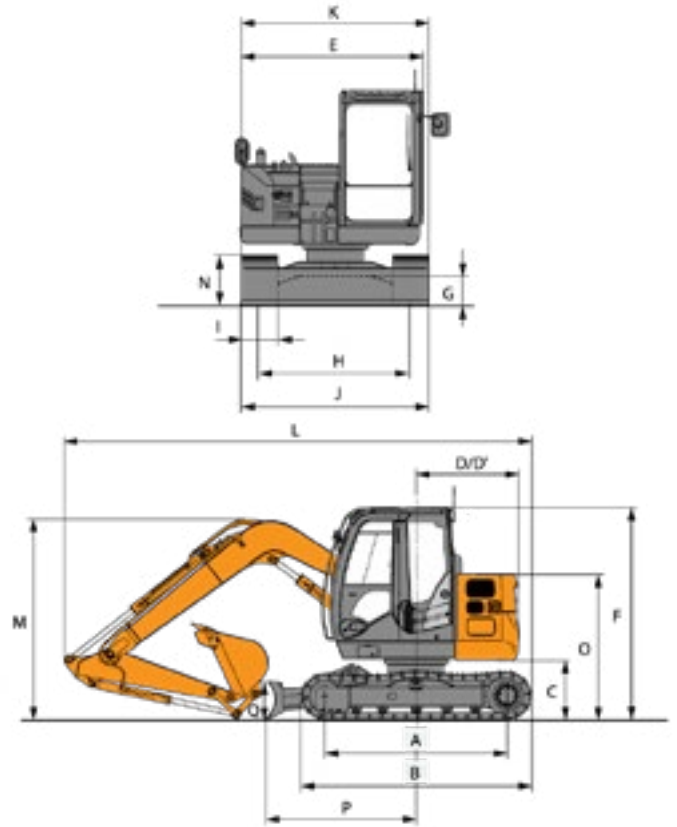
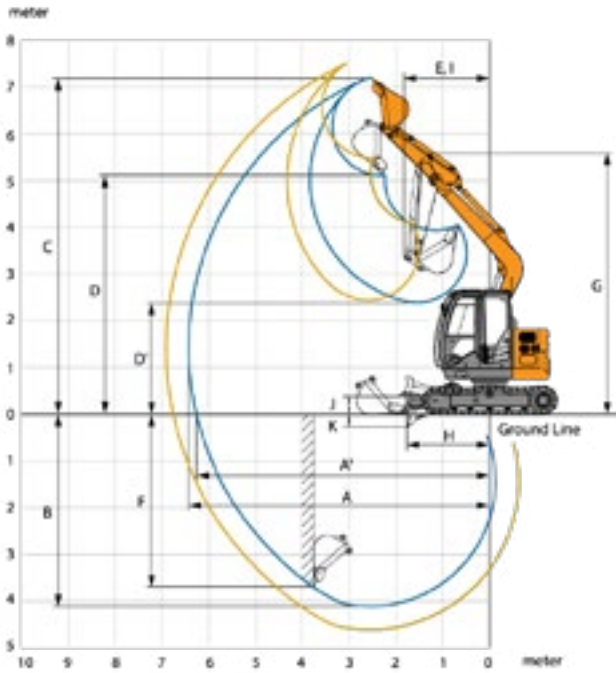

A	Max. digging reach	6 920	A	Distance between tumblers	2 290
A'	Max. digging reach (on ground)	3 310	B	Undercarriage length	2 920
B	Max. digging depth	4 610	*C	Counterweight clearance	730
C	Max. cutting height	7 610	D	Rear-end swing radius	1 490
D	Max. dumping height	5 510	D'	Rear-end length	1 490
D'	Min. dumping height	2 410	E	Overall width of upper structure	2 260
E	E Min. swing radius	2 170	F	Overall height of cab	2 690
F	Max. vertical wall	4 220	*G	Min. ground clearance	360
G	Front height at Min. swing radius	5 610	H	Track gauge	1 870
H	Min. level crowding distance	1 670	I	Track shoe width	450
I	Working radius at Min. swing radius (Max. boom-swing angle)	-	J	Undercarriage width	2 000
			K	Overall width	2 000

## STANDARD FEATURES

- Multi gauge capability
- All attachments are interchangeable between ZX65, Zx85 and the ZX95
- Rubber pads
- Engcon EC206 Tilt rotator with integrated grabs

## LIFTING

Original Equipment Manufacturer tested and approved Safe Work Load on rail. This is the only Road rail excavator in its size class to have an OEM engineering approval on a SWL while on rail.

## RAIL NETWORKS APPROVED TO WORK ON:

- TfNSW ASA rolling stock certified
- Sydney Trains Plant Hire services
- John Holland Rail Australia wide
- Laing O'Rourke
- NOVO Rail
- Select Plant Hire

